

REP	N° DAK	DESCRIPTION	QTE
1	07.002827-C	KIT CAPTEUR 001-20_V20	1
2	07.002833-D	KIT PT 001-20_V19/V20 - 001-25_V20	1

REVISIONS		
REV	DESCRIPTION	DATE
D	07.002833-D était 07.002833-C	11/06/2021

DAK
INDUSTRIES

Informations contained in this drawing are the sole properties of DAK INDUSTRIES. Reproduction in part or whole without the written permission is prohibited.

LINEAR DIMENSIONS ARE IN MILLIMETERS.
ANGULAR DIMENSIONS ARE IN DEGREES.
GENERAL TOLERANCES ACCORDING TO:
-

MATERIAL :
-

FINISH :
-

WEIGHT : 47 Kg

NAME : CESC 001-20_V20 PT

NAME	DATE & SIGNATURE
DESIGNER J.BRIARD	
CHECKER F.MYKIETA	
METHODS F.MYKIETA	
SCALE : 1:15 SIZE : A3 CREATION DATE : 11/05/2021	N° DAK INDUSTRIES REVISION : 07.002846 - D STATUS : STANDARD
PAGE: 1/1	

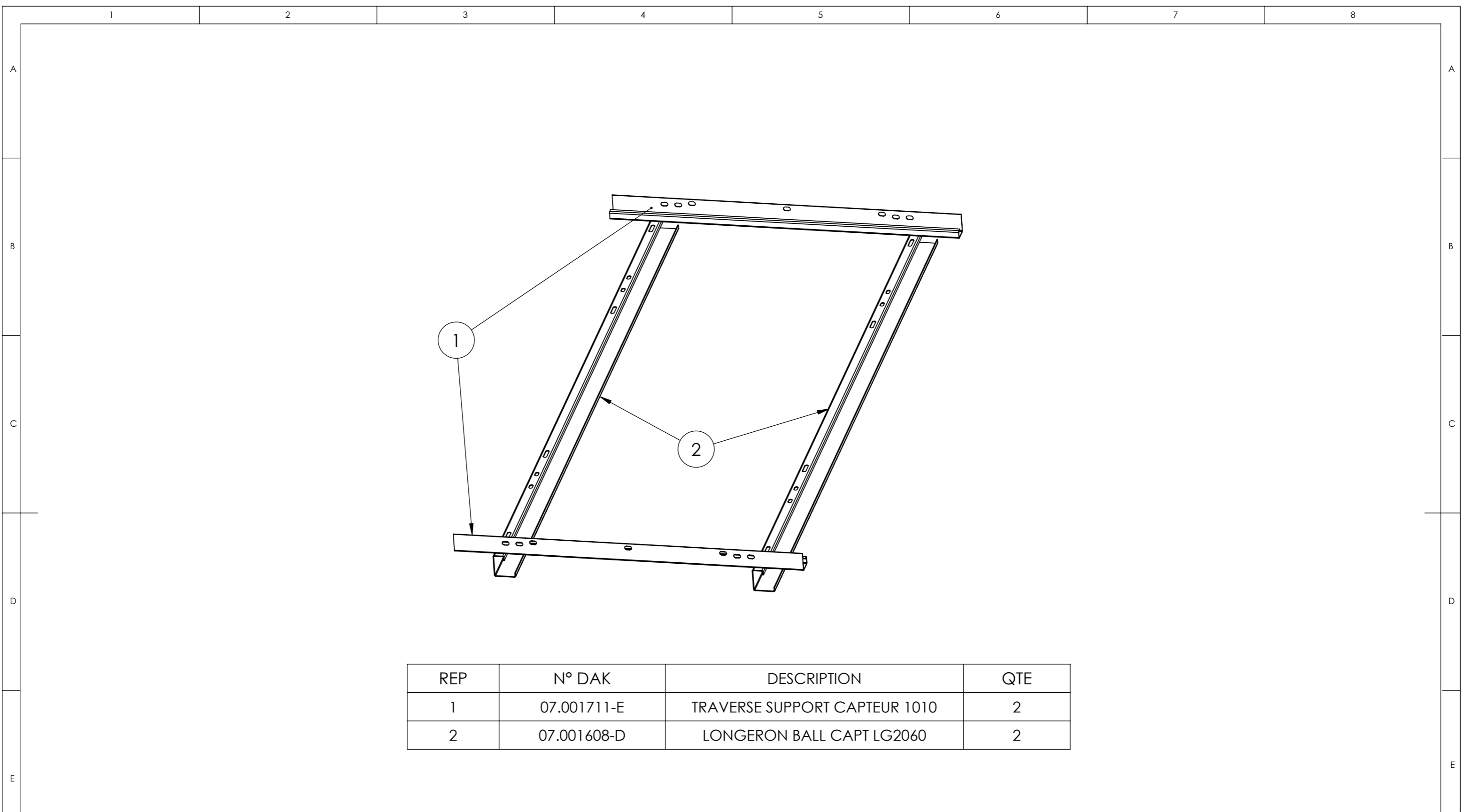

REP	N° DAK	DESCRIPTION	QTE
1	07.001711-E	TRAVERSE SUPPORT CAPTEUR 1010	2
2	07.001608-D	LONGERON BALL CAPT LG2060	2

REVISIONS		
REV	DESCRIPTION	DATE
D	07.001608-D était 07.001608-C	11/06/2021

DAK INDUSTRIES

Informations contained in this drawing are the sole properties of DAK INDUSTRIES. Reproduction in part or whole without the written permission is prohibited.

LINEAR DIMENSIONS ARE IN MILLIMETERS. ANGULAR DIMENSIONS ARE IN DEGREES. GENERAL TOLERANCES ACCORDING TO:

MATERIAL : - FINISH : -

WEIGHT : 15 Kg NAME : KIT PT 001-20_V19/V20 - 001-25_V20

DESIGNER	NAME	DATE & SIGNATURE
J.BRIARD	J.BRIARD	
F.MYKIETA	F.MYKIETA	
F.MYKIETA	F.MYKIETA	
SCALE : 1:10		N° DAK INDUSTRIES REVISION : 07.002833 - D
SIZE : A3		
CREATION DATE : 10/05/2021		STATUS : STANDARD
PAGE: 1/3		

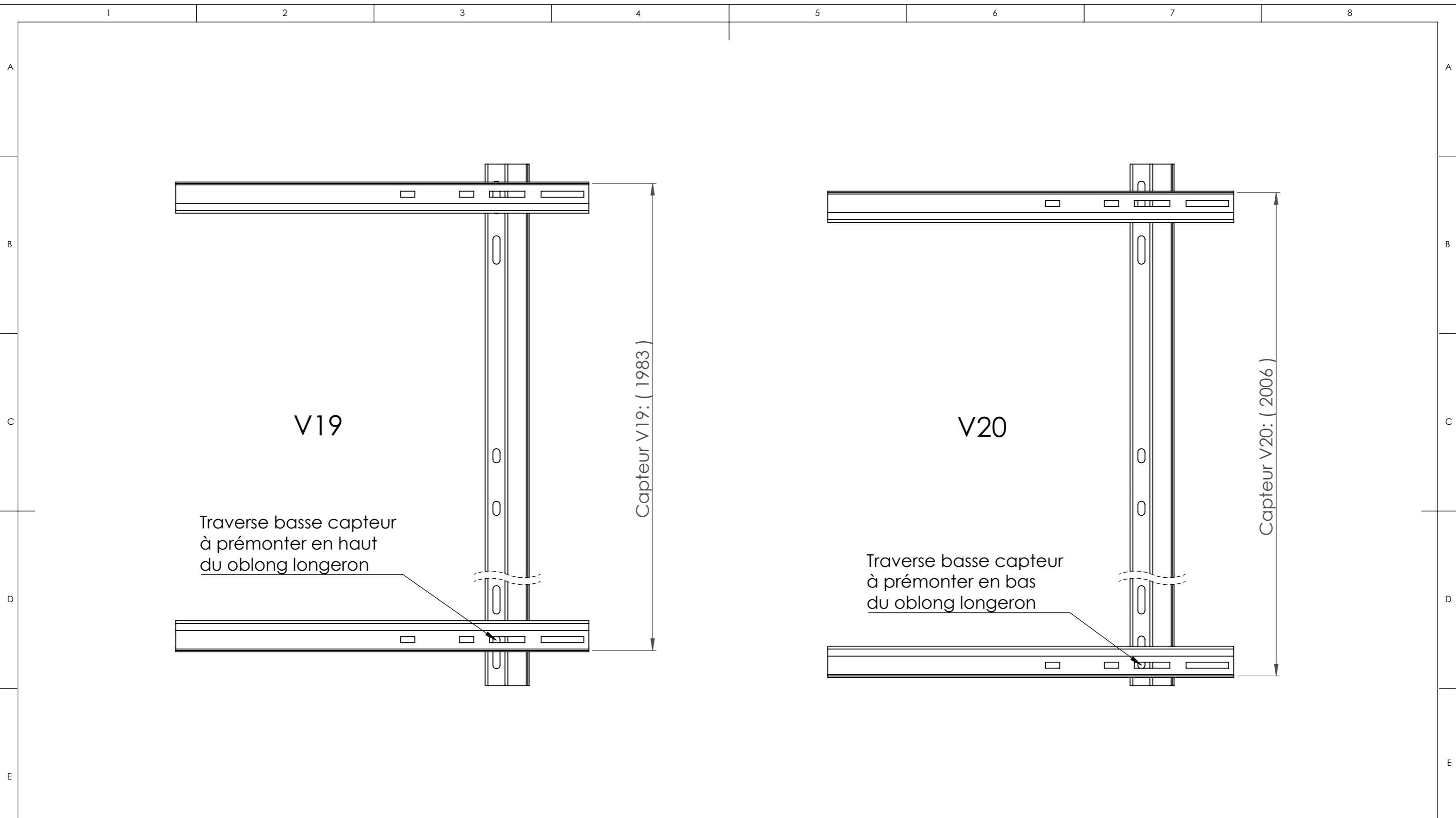

REVISIONS		
REV	DESCRIPTION	DATE
D	Voir page 1	11/06/2021

DAK INDUSTRIES

Informations contained in this drawing are the sole properties of DAK INDUSTRIES. Reproduction in part or whole without the written permission is prohibited.

LINEAR DIMENSIONS ARE IN MILLIMETERS.
ANGULAR DIMENSIONS ARE IN DEGREES.
GENERAL TOLERANCES ACCORDING TO:
-

MATERIAL :
-

FINISH :
-

WEIGHT : 15 Kg

NAME	DATE & SIGNATURE
DESIGNER J.BRIARD	
CHECKER F.MYKIETA	
METHODS F.MYKIETA	
SCALE : 1:5	N° DAK INDUSTRIES REVISION : 07.002833 - D
SIZE : A3	
CREATION DATE : 10/05/2021	STATUS : STANDARD
NAME : KIT PT 001-20_V19/V20 - 001-25_V20	PAGE: 2/3

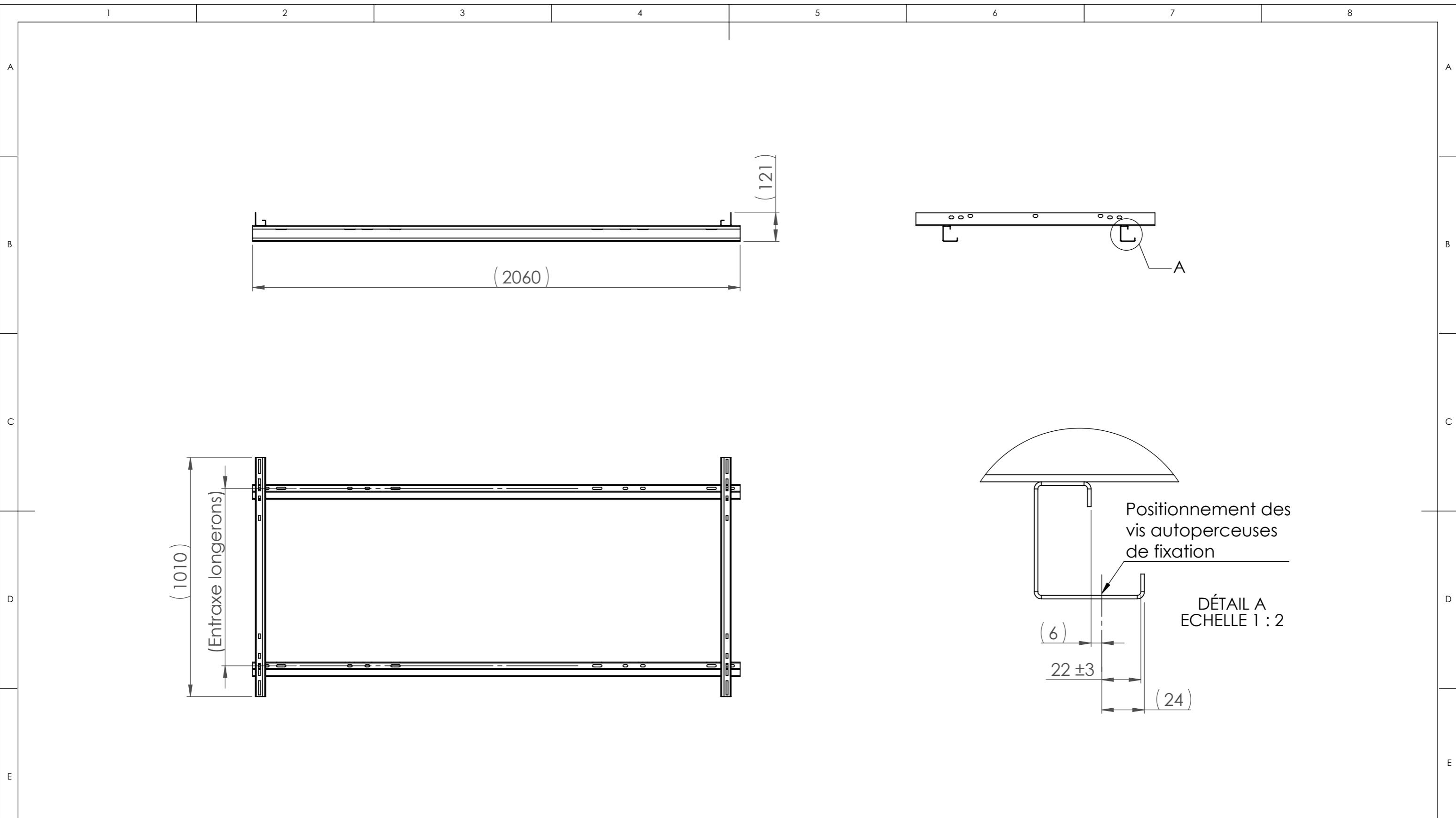

REVISIONS		
REV	DESCRIPTION	DATE
D	Voir page 1	11/06/2021

DAK INDUSTRIES

Informations contained in this drawing are the sole properties of DAK INDUSTRIES. Reproduction in part or whole without the written permission is prohibited.

LINEAR DIMENSIONS ARE IN MILLIMETERS. ANGULAR DIMENSIONS ARE IN DEGREES. GENERAL TOLERANCES ACCORDING TO:

MATERIAL : - FINISH : -

WEIGHT : 15 Kg NAME : KIT PT 001-20_V19/V20 - 001-25_V20

DESIGNER	NAME	DATE & SIGNATURE
J.BRIARD	J.BRIARD	
F.MYKIETA	F.MYKIETA	
F.MYKIETA	F.MYKIETA	
SCALE : 1:15 SIZE : A3		N° DAK INDUSTRIES REVISION : 07.002833 - D STATUS : STANDARD
CREATION DATE : 10/05/2021		
PAGE: 3/3		