

REP	N° DAK	DESCRIPTION	QTE
1	07.002827-C	KIT CAPTEUR 001-20_V20	1
2	07.002835-C	KIT TR2 001-20_V19/V20 - 001-25_V20	1

REVISIONS		
REV	DESCRIPTION	DATE
D	Correction: WEIGHT: 59Kg était WEIGHT: 63Kg	11/06/2021

DAK
INDUSTRIES

Informations contained in this drawing are the sole properties of DAK INDUSTRIES. Reproduction in part or whole without the written permission is prohibited.

LINEAR DIMENSIONS ARE IN MILLIMETERS.
ANGULAR DIMENSIONS ARE IN DEGREES.
GENERAL TOLERANCES ACCORDING TO:
-

MATERIAL :
-

FINISH :
-

WEIGHT : 59 Kg

NAME : CESC 001-20_V20 TR2

NAME	DATE & SIGNATURE
DESIGNER J.BRIARD	
CHECKER F.MYKIETA	
METHODS F.MYKIETA	
SCALE : 1:15	N° DAK INDUSTRIES REVISION : 07.002854 - D
SIZE : A3	
CREATION DATE : 12/05/2021	STATUS : STANDARD
PAGE : 1/1	

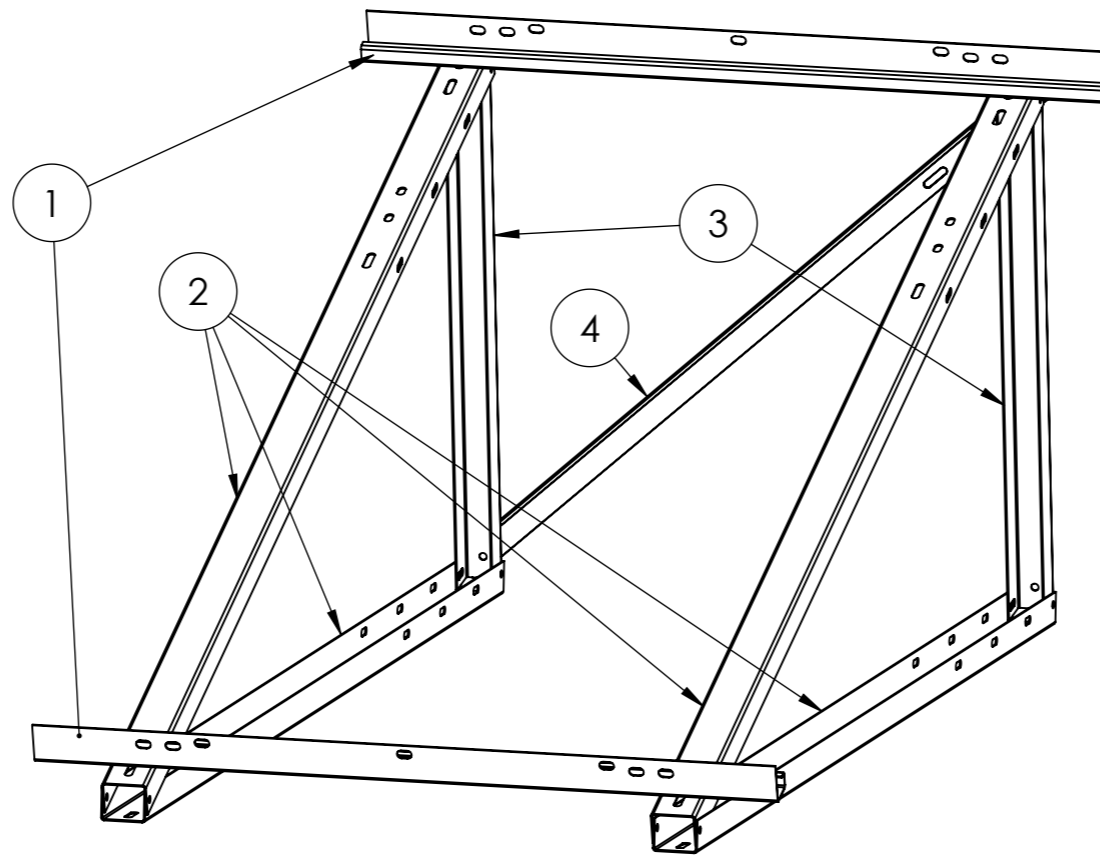

REP	N° DAK	DESCRIPTION	QTE
1	07.001711-E	TRAVERSE SUPPORT CAPTEUR 1010	2
2	07.000199-C	LONGERON TR LG2060	4
3	07.000361-C	PIEDS AR BRACON 20°	2
4	07.000358-C	DEMI CROISILLON LG1077	1

REVISIONS		
REV	DESCRIPTION	DATE
		xx/xx/20xx

DAK
INDUSTRIES

Informations contained in this drawing are the sole properties of DAK INDUSTRIES. Reproduction in part or whole without the written permission is prohibited.

LINEAR DIMENSIONS ARE IN MILLIMETERS.
ANGULAR DIMENSIONS ARE IN DEGREES.
GENERAL TOLERANCES ACCORDING TO:
-

MATERIAL :
-

FINISH :
-

WEIGHT : 27 Kg

NAME	DATE & SIGNATURE
DESIGNER J.BRIARD	
CHECKER F.MYKIETA	
METHODS F.MYKIETA	

SCALE : 1:10
SIZE : A3
CREATION DATE : 12/05/2021

N° DAK INDUSTRIES REVISION :
07.002835 - C
STATUS : STANDARD

NAME : KIT TR2 001-20_V19/V20 - 001-25_V20

PAGE: 1/3

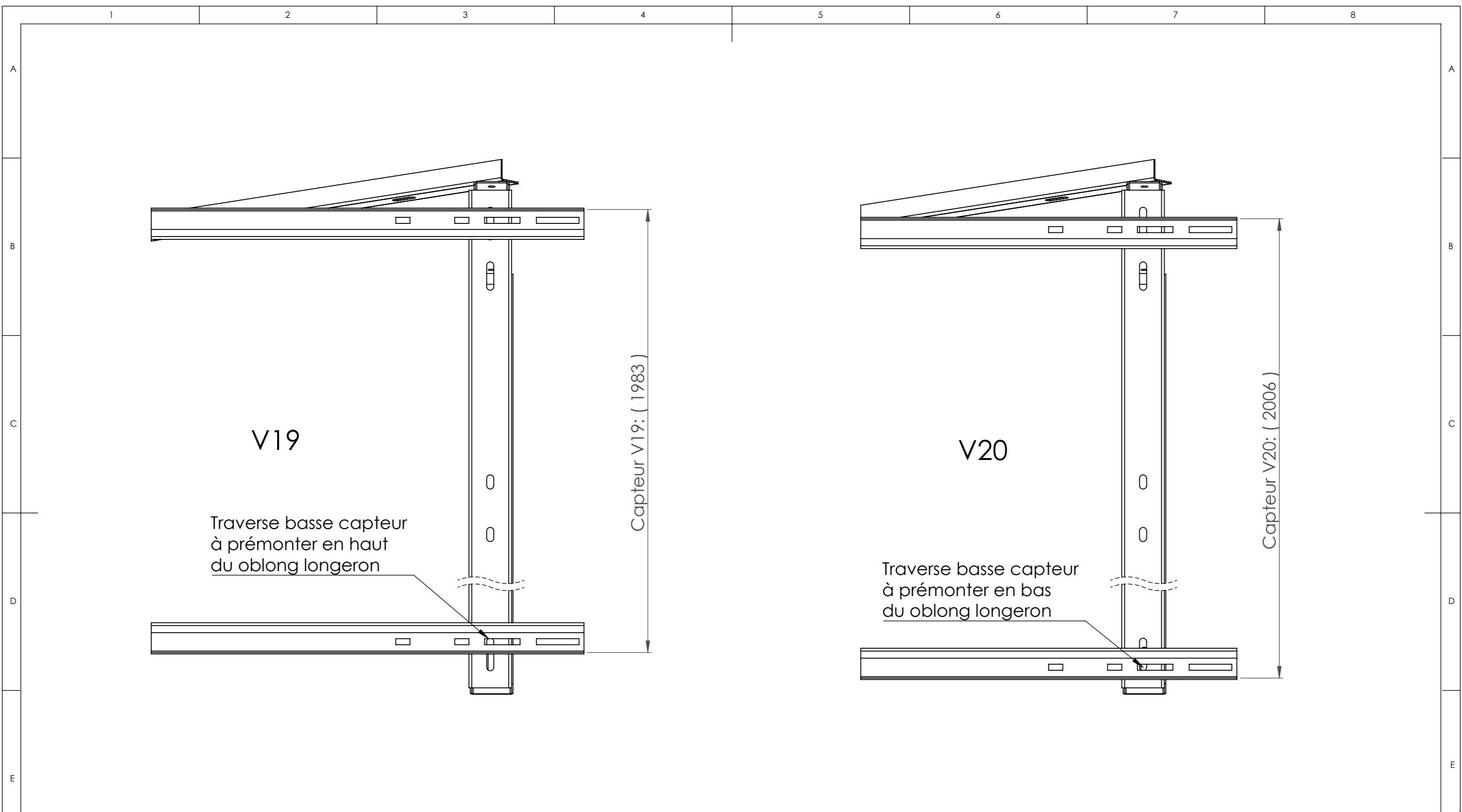

REVISIONS		
REV	DESCRIPTION	DATE
		xx/xx/20xx

DAK INDUSTRIES

Informations contained in this drawing are the sole properties of DAK INDUSTRIES. Reproduction in part or whole without the written permission is prohibited.

LINEAR DIMENSIONS ARE IN MILLIMETERS.
ANGULAR DIMENSIONS ARE IN DEGREES.
GENERAL TOLERANCES ACCORDING TO:

MATERIAL :
-

FINISH :
-

WEIGHT : 27 Kg

NAME	DATE & SIGNATURE
DESIGNER J.BRIARD	
CHECKER F.MYKIETA	
METHODS F.MYKIETA	
SCALE : 1:5	N° DAK INDUSTRIES REVISION : 07.002835 - C
SIZE : A3	
CREATION DATE : 12/05/2021	STATUS : STANDARD
NAME : KIT TR2 001-20_V19/V20 - 001-25_V20	
PAGE: 2/3	

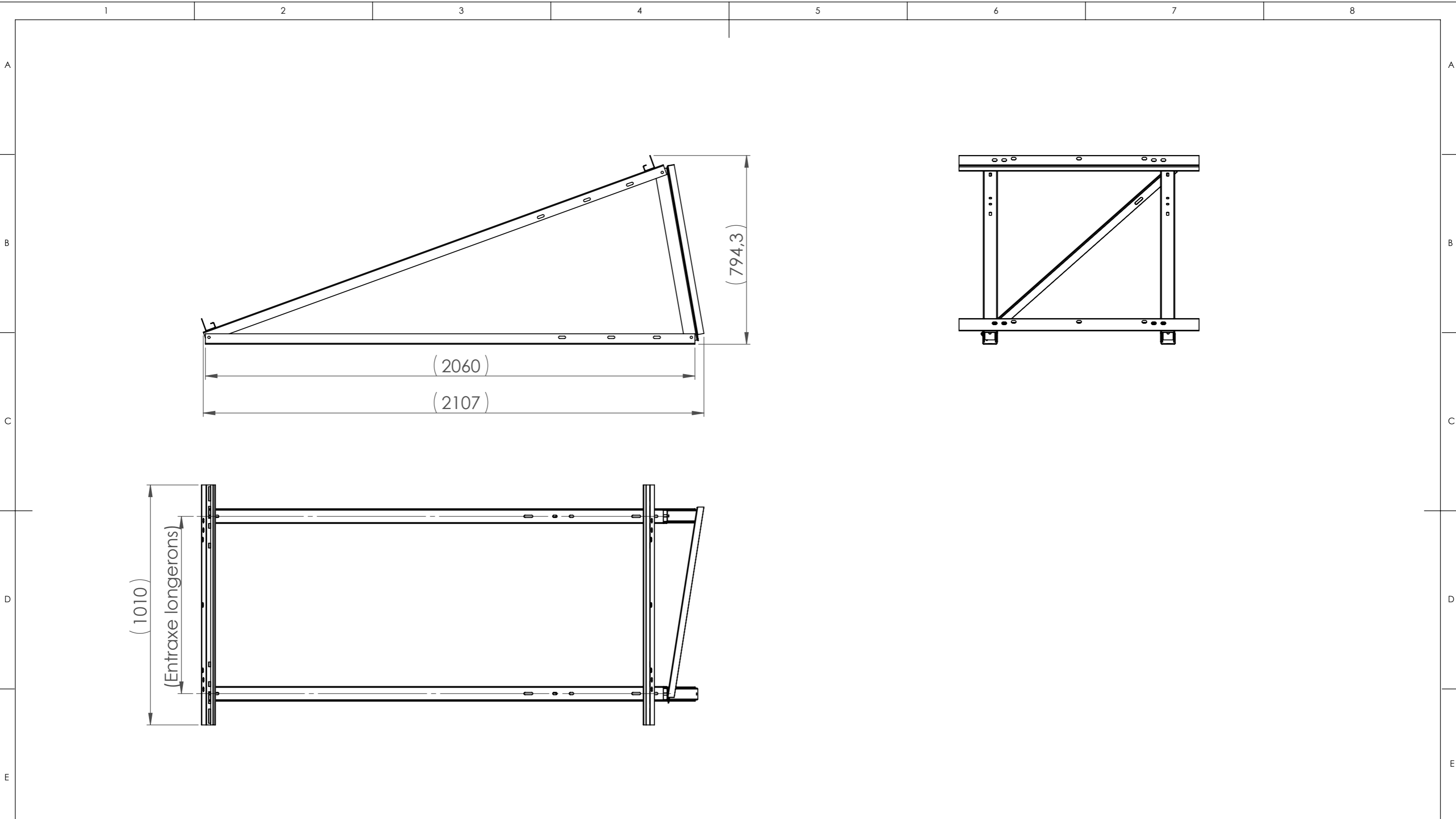

REVISIONS		
REV	DESCRIPTION	DATE
		xx/xx/20xx

DAK INDUSTRIES

Informations contained in this drawing are the sole properties of DAK INDUSTRIES. Reproduction in part or whole without the written permission is prohibited.

LINEAR DIMENSIONS ARE IN MILLIMETERS. ANGULAR DIMENSIONS ARE IN DEGREES. GENERAL TOLERANCES ACCORDING TO:

MATERIAL : - FINISH : -

WEIGHT : 27 Kg NAME : KIT TR2 001-20_V19/V20 - 001-25_V20

DESIGNER	NAME	DATE & SIGNATURE
J.BRIARD		
F.MYKIETA		
F.MYKIETA		
SCALE : 1:15	N° DAK INDUSTRIES REVISION :	
SIZE : A3	07.002835 - C	
CREATION DATE : 12/05/2021	STATUS : STANDARD	
		PAGE: 3/3